

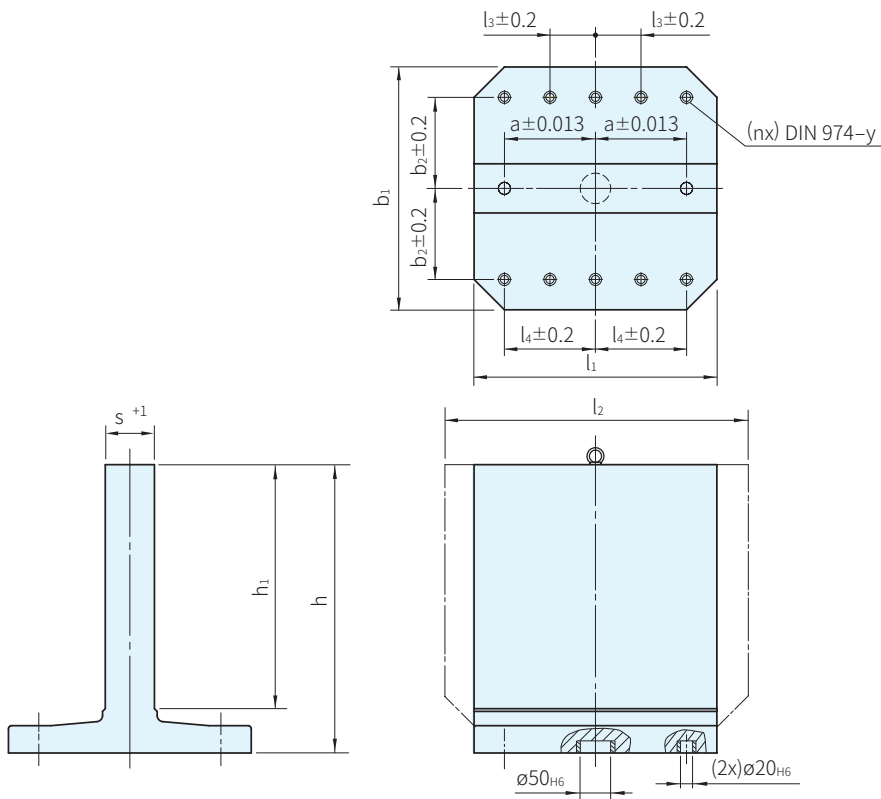

材質	處理
鑄鋼	燒鈍



品號	$b_1 \times l_1$	$l_2$	$h_1$	$h$	$a$	$b_2$	$l_3$	$l_4$	$s$	$y$	螺絲用	固定孔數量 N	質量 kg	庫存
1906.210	400×400	-	400	475	150	150	-	150	81	12	M12	4	150	△
1906.310	400×400	500	400	475	150	150		150	81	12	M12	4	173	△
1906.410	500×500	-	500	595	200	200		200	101	12	M12	6	284	△
1906.510	500×500	630	500	595	200	200		200	101	12	M12	6	334	△
1906.610	630×630	-	630	725	200	200		200	131	16	M16	6	1.23	△
1906.810	800×800	-	800	910	300	300	100	300	151	16	M16	8	805	△

訂貨：  交期：

1906.210